

## TRANSLATION OF ORIGINAL INSTRUCTIONS

PNEUMATIC RIVETING TOOL  
FOR RIVETS  $\varnothing 2.4 \div \varnothing 4.8$   
( $\varnothing 4.8$  ALUMINIUM ONLY)

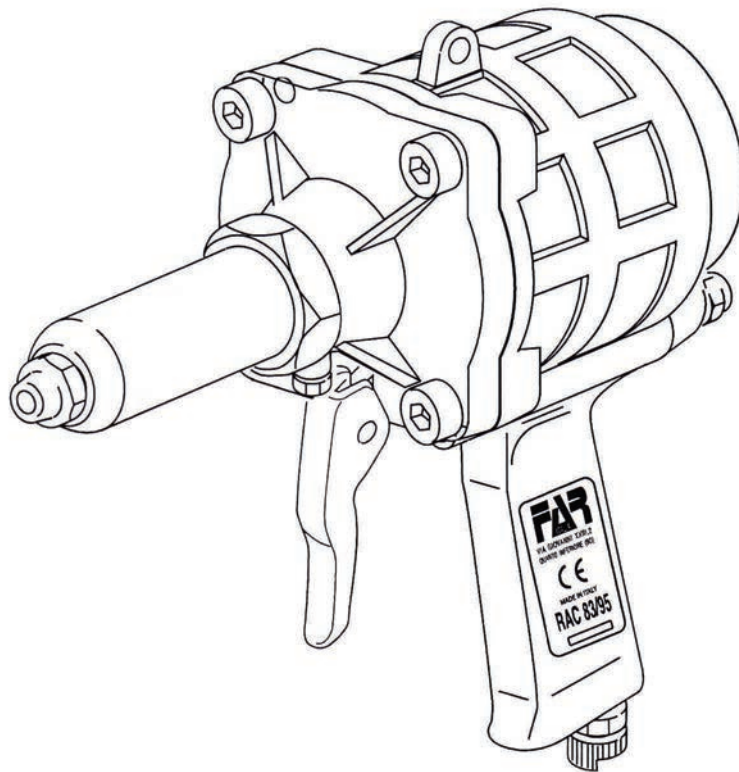

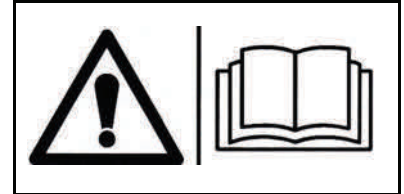

The undersigned Far S.r.l., having its office in Quarto Inferiore (BO), Via Giovanni XXIII No. 2, herewith

**DECLARES**

on its sole responsibility that the riveting machine

Type: RAC 83/95 - Pneumatic tool Application: for rivets diameter. 2.4—4.8 mm (4.8 aluminum only)

which is the object of this declaration complies with the basic safety requirements established in the law decree Leg. D. 17/2010 of Machinery Directive 2006/42/CE acknowledge and subsequent amendments and integrations.

The person who is authorized to create the technical brochure is

Giacomo Generali, c/o Far S.r.l., head office in Quarto Inferiore (BO), via Giovanni XXIII n. 2.

Quarto Inferiore, 23-03-2010

A handwritten signature in black ink, appearing to read 'Giacomo Generali'.

**Far S.r.l. – Giacomo Generali**  
(Chairman of the Board of Directors)

**GENERAL NOTES AND USE**

The tool must be used for rivets diam. 2.4 - 4.8mm **only**.

Diameter is 4.8 mm only in aluminum.

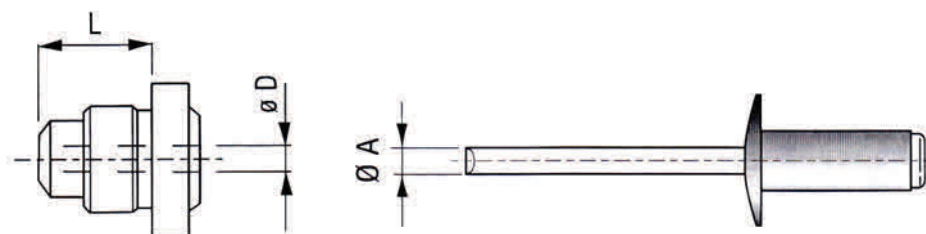

Code	L	Ø D	Ø A ÷
717001	8.5	2.25	1.7 ÷ 2.1
717002	10	2.7	2.15 ÷ 2.4
717003	11.2	3.1	2.6 ÷ 2.75
717004	12.5	3.4	2.9 ÷ 3.2
717005	14	4	3.4 ÷ 3.5
717006	7	1.9	1.43

**DISPOSAL OF THE RIVETING TOOL**

Follow the prescriptions of the national laws for disposing of the riveting tool.

After disconnecting the tool from the pneumatic system, disassemble and split all the components according to the material: steel, aluminium, plastic material, etc.

Then proceed to scrap the materials in accordance with current laws.



## INSTRUCTIONS FOR USE

### INDEX

GUARANTEE	4
SAFETY MEASUREMENTS & REQUIREMENTS	4
MAIN COMPONENTS	4
TOOL IDENTIFICATION	5
TECHNICAL DATA	5
MAINTENANCE & CHANGE OF SIZE	5

### GUARANTEE

FAR riveting tools are covered by a **12-month** warranty. The tool warranty period starts on the date of delivery to the buyer, as specified in the relevant document. The warranty covers the user/buyer provided that the tool is purchased through an authorized dealer and only if it is used for the purposes for which it was conceived. The warranty shall not be valid if the tool is not used or maintained as specified in the instruction and maintenance handbook. In the event of defects or failures, **FAR S.r.l.** shall undertake solely to repair and/or replace the components it judges to be faulty.

### SAFETY MEASURES & REQUIREMENTS



#### CAUTION!!!

All the operations must be done in conformity with the safety requirements, in order to avoid any consequence for your and other people's security and to allow the best tool work way.

- Read the instructions carefully before using the tool.
- For all maintenance and/or repairs please contact **FAR s.r.l.** authorized service centers and use only **original spare parts**. **FAR s.r.l.** may not be held liable for damages from defective parts caused by failure to observe what above mentioned (**EEC directive 85/374**).
- The tool must be used only by expert workers.
- A protective visor and gloves must be put on when using the tool.
- Use equipment recommended in the maintenance chapter to do any maintenance and/or regulation of the tool.
- For topping up the oil, we suggest using only fluids in accordance with the features specified in this working book.
- If any drop of oil touches your skin, you must wash with water and alkaline soap.
- The tool can be carried and we suggest putting it into its box after using.
- The tool needs a thorough six-monthly overhaul.
- Repairing and cleaning operations must be done when the tool is not fed.
- If it is possible, we suggest a safety balancer.
- If the A-weighted emission sound pressure level is more than 70 dB (A), you must use some hearing protections (anti-noise headset, etc.).

- The workbench and the work surface must be always clean and tidy. The untidy can cause damages to people.
- Do not allow unauthorized persons to use the working tools.
- Make you sure that the compressed air feeding hoses have the correct size to be used.
- Do not carry the connected tool by pulling the hose. The hole must be far from any heating sources or from cutting parts.
- Keep the tools in good conditions; do not remove either safety parts or silencers.
- After repairing and/or adjusting, make sure you have already removed the adjusting spanners.
- Before disconnecting the compressed air hose from the tool make sure that there is no pressure in the hose.
- These instructions must be carefully followed.

### MAIN COMPONENTS

- A) Nozzle
- B) Balancer connection
- C) Tensile strength trigger
- D) Compressed air connection
- E) Head carrying nozzle

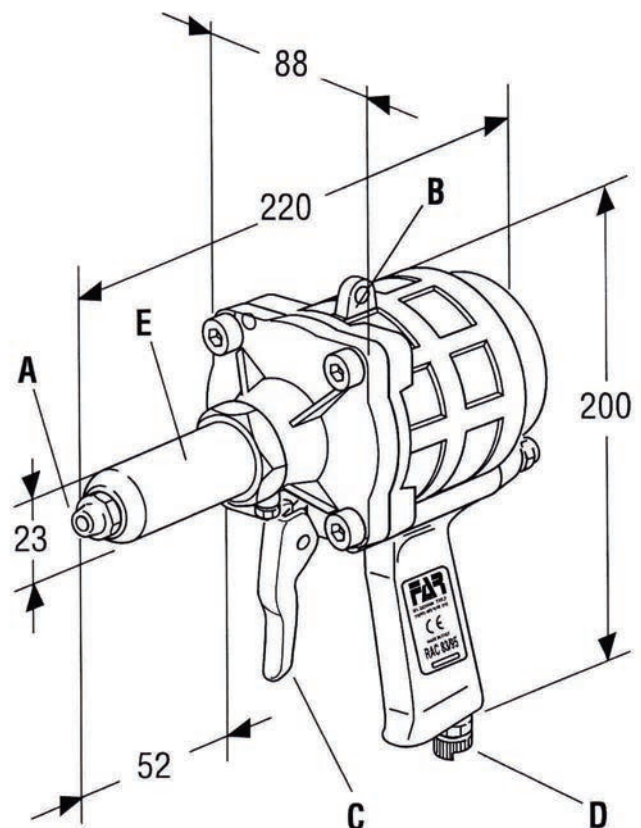



**TOOL IDENTIFICATION**

The riveting tool **RAC 83 AX** is identified from a marking that shows company name and address of manufacturer, designation of the tool, CE mark and year of manufacturing. If any service is requested, please make reference to the data shown on the marking.



**TECHNICAL DATA**

- Working pressure **6 BAR**
- Min. int. diam. Of the compressed air feeding hose **Min. diam = 8 mm**
- Air consumption per cycle **2.2 NI**
- Maximum force **6 BAR – 5372 N**
- Weight **1.74 Kg**
- Working temperature **-5°/+50°**
- Root mean square in total acceleration frequency (Ac) to which the arms are subjected **3.3 m/s<sup>2</sup>**
- A-weighted emission sound pressure level **86 dBA**
- Peak C-weighted instantaneous sound pressure **<130 dBC**
- A-weighted emission sound pressure **94 dBA**

**AIR FEED**

The air feed must be free from foreign bodies and humidity in order to protect the tool from premature wear and tear of the components in movement, therefore we suggest to use a lubricator group for compressed air.

**MAINTENACE AND CHANGE OF SIZE (fig. f1)**

The extended utilization of the riveting tool can cause the slipping of the clamps on the nail due to the deposited impurities. For this reason, it is necessary to lubricate the clamps after having cleaned them. However, if clamps are worn out and as a consequence their working is jeopardized, replace them. First remove the head which carries the nozzle (E), by means of a standard spanner of 27 mm. Then, by using two spanners of 15 mm and 16 mm, remove the chuck (F) and extract the clamps (G).

When replacing the nozzle (A), we recommend to use a 12-mm standard spanner and fit the removed nozzle in the proper housing located on the bottom of your riveting tool, in order to avoid losing the nozzle.

**WARNING!**  
 Disconnect air feed when performing those operations.

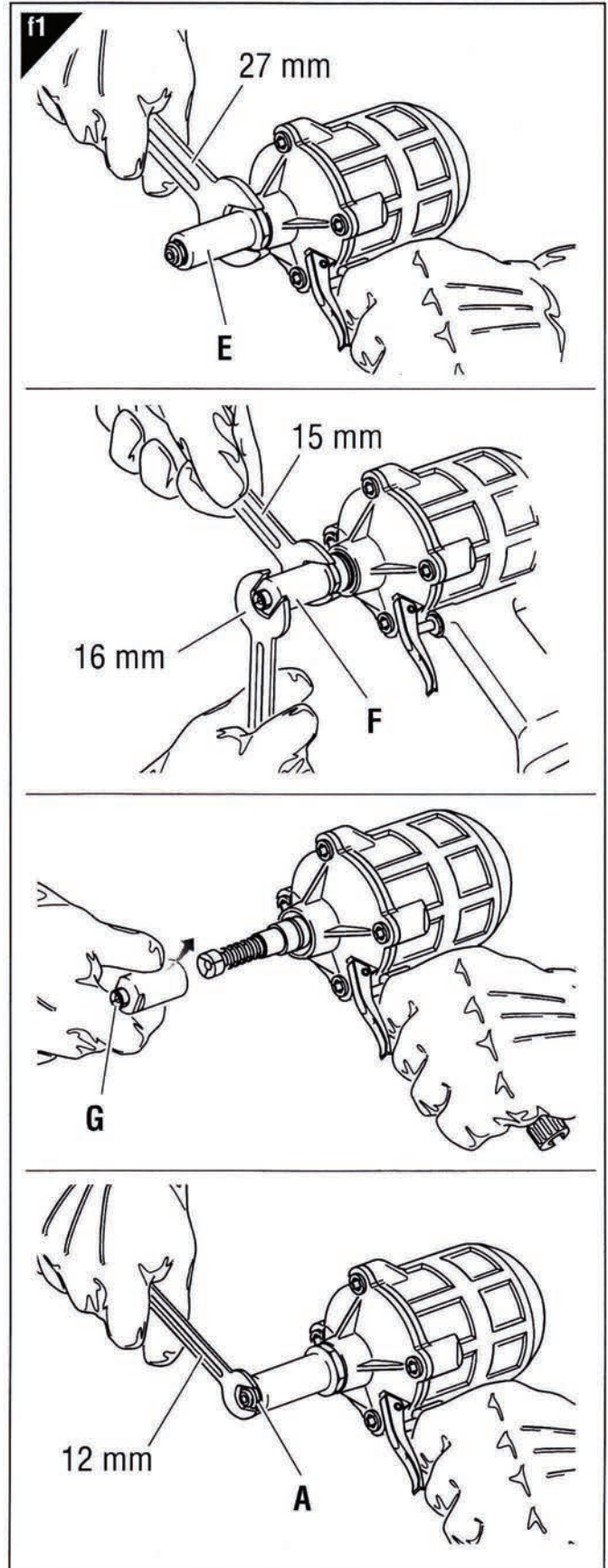

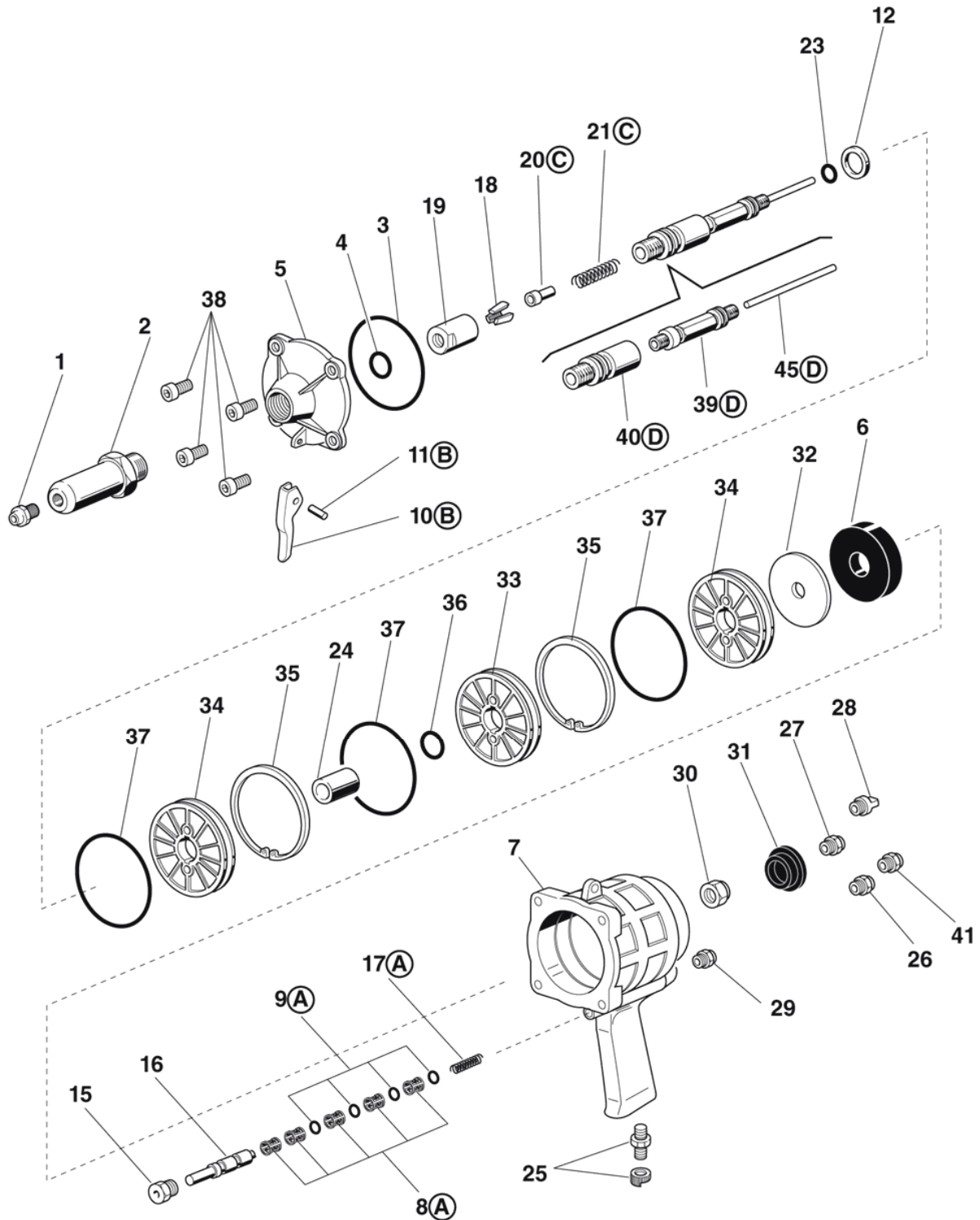

**8A(x5)**    **9A(x4)**  
  
**17A(x1)**  
**KIT A**

**11B(x1)**  
  
**10B(x1)**  
**KIT B**

**20C(x1)**    **21C(x1)**  
  
**KIT C**

**40D(x1)**    **39D(x1)**    **45D(x1)**  
**KIT D**

Pos.	Code	Description	Qty
01	717003	Nozzle for rivet ø 4,8 All.	1
02	710513	Sleeve carrying nozzle	1
03	710294	Gasket OR 150	1
04	710420	Gasket OR 210	1
05	710534	Cover	1
06	710422	Shock absorber	1
07	710535	Riveting tool body	1
08A	710188	Cage	5
09A	710187	Gasket OR 109	4
10B	710536	Push-button	1
11B	710537	Spring pin ø 4 x 12 UNI 6873	1
12	710426	Washer	1
15	710538	Ring nut	1
16	710539	Coil	1
17A	710540	Coil return spring	1
18	710011	Clamps	3
19	710431	Clamps holding cone	1
20C	710544	Clamps opener	1
21C	710515	Clamps return spring	1
23	710427	Gasket OR 013	1
24	710542	Bush	1
25	710173	Milled nut connector 1/4"	1
26	717001	Nozzle for rivet ø 2,5 ÷ 3,4	1
27	717006	Nozzle for rivet ø 2,4	1
28	710438	Balancer hook	1
29	710219	Silencer 1 SEP 1/8"	1
30	710302	Nut M 12 UNI 7474	1
31	710439	Cap	1
32	710243	Shock absorber disc	1
33	710442	Fixed piston	1
34	710443	Movable piston	2
35	710295	Seeger ring 78 UNI 7437	2
36	710444	Gasket OR 211	1
37	710335	Gasket OR 844	3
38	710670	Screw TCCE M6 x 12 UNI 5931	4
39D	710958	Shaft	1
40D	710707	Cone holder	1
41	717002	Nozzle for rivet ø 4	1
45D	711938	Shaft extension	1

<b>KITA</b>	<b>740188</b>	<b>Cage kit</b>	
	<b>Code</b>	<b>Description</b>	<b>Qty</b>
	710188	Cage	5
	710187	Gasket OR 109	4
	710540	Coil return spring	1

<b>KITB</b>	<b>740536</b>	<b>Push-button kit</b>	
	<b>Code</b>	<b>Description</b>	<b>Qty</b>
	710536	Push-button	1
	710537	Spring pin $\varnothing$ 4 x 12 UNI 6873	1

<b>KITC</b>	<b>740544</b>	<b>Clamps opener kit</b>	
	<b>Code</b>	<b>Description</b>	<b>Qty</b>
	710544	Clamps opener	1
	710515	Clamps return spring	1

<b>KITD</b>	<b>740707</b>	<b>Cone holder kit</b>	
	<b>Code</b>	<b>Description</b>	<b>Qty</b>
	710958	Shaft	1
	710707	Cone holder	1
	711938	Shaft extension	1